

**Side View**  
Flush Mount; No Links

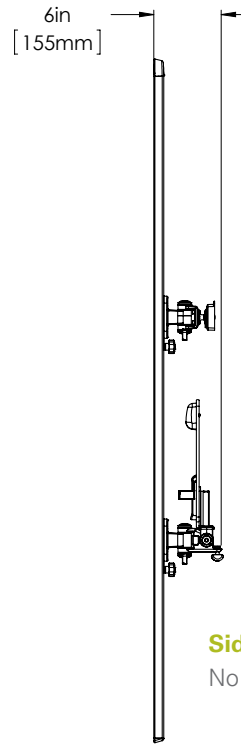

**Side View**  
No Links

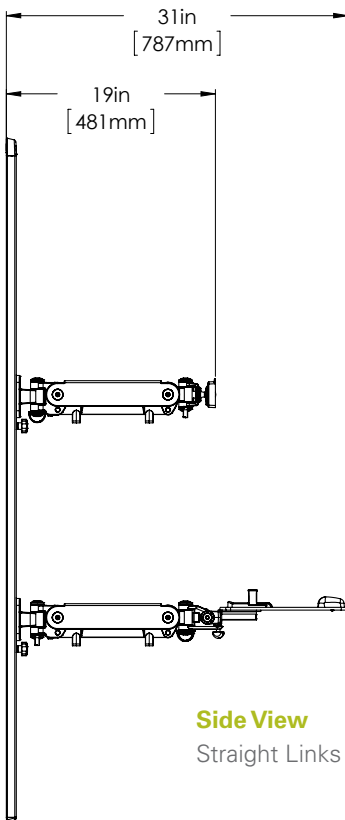

**Side View**  
Straight Links

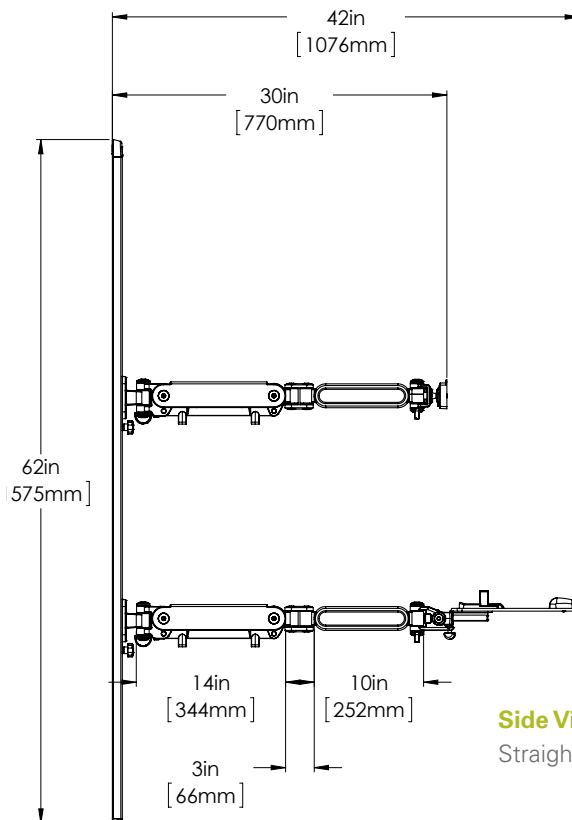

**Side View**  
Straight Links

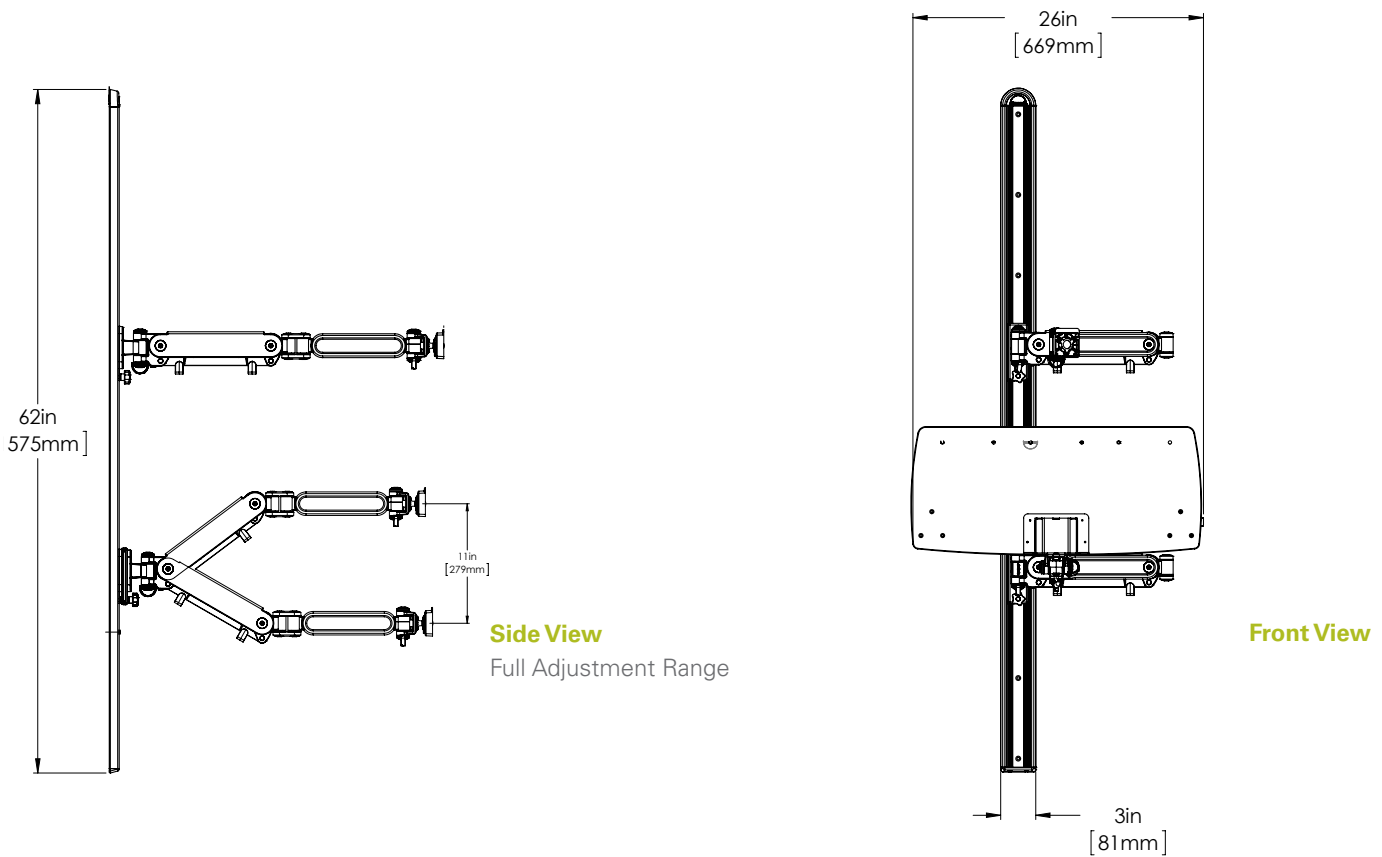

## Packaging Specs

### The V5 will be sent in two boxes:

- Component Box: 26 H x 16 W x 14 D, 30 lbs\*  
(weight varies depending upon arm configuration. This weight is for dual link arms with SHP)
- Track Box: Dimensions and weight vary with track length. See Below
- 25 units per skid

### Master Carton Dimensions and Weights for V5 Track Lengths

36" Track	Dimensions: 39.17" H x 7.48 W x 4.53" D*	Weight 25.35 lbs* (5PCS PER BOX)
48" Track	Dimensions: 51.18" H x 7.48 W x 4.53" D*	Weight 33.07 lbs* (5PCS PER BOX)

### Accessory Mount Assembly

- Master Carton Dimensions: 17.9" H x 11.2" W x 9.3" D
- Master Carton Weight: 0.3 lb. (net weight); 28.0 lbs. (gross weight)
- Number of Pieces in Master Carton: 80

### 5 year warranty

\*Approximate